

POWERED MULTIMEDIA SPEAKERS

YST-MS50(M)

SERVICE MANUAL

The contents of this Service Manual are applicable to the products with serial numbers of Z200001 and up.

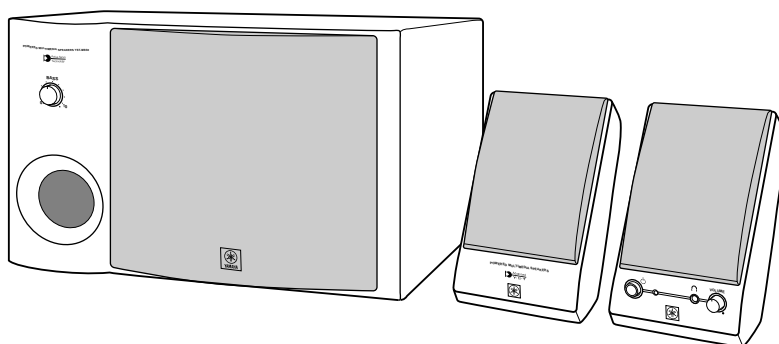

IMPORTANT NOTICE

This manual has been provided for the use of authorized YAMAHA Retailers and their service personnel. It has been assumed that basic service procedures inherent to the industry, and more specifically YAMAHA Products, are already known and understood by the users, and have therefore not been restated.

WARNING: Failure to follow appropriate service and safety procedures when servicing this product may result in personal injury, destruction of expensive components, and failure of the product to perform as specified. For these reasons, we advise all YAMAHA product owners that any service required should be performed by an authorized YAMAHA Retailer or the appointed service representative.

IMPORTANT: The presentation or sale of this manual to any individual or firm does not constitute authorization, certification or recognition of any applicable technical capabilities, or establish a principle-agent relationship of any form.

The data provided is believed to be accurate and applicable to the unit(s) indicated on the cover. The research, engineering, and service departments of YAMAHA are continually striving to improve YAMAHA products. Modifications are, therefore, inevitable and specifications are subject to change without notice or obligation to retrofit. Should any discrepancy appear to exist, please contact the distributor's Service Division.

WARNING: Static discharges can destroy expensive components. Discharge any static electricity your body may have accumulated by grounding yourself to the ground buss in the unit (heavy gauge black wires connect to this buss).

IMPORTANT: Turn the unit OFF during disassembly and part replacement. Recheck all work before you apply power to the unit.

CONTENTS

TO SERVICE PERSONNEL	1
FRONT AND REAR PANELS	1 - 2
SPECIFICATIONS	3
INTERNAL VIEW	4
DISASSEMBLY PROCEDURES	5

PRINTED CIRCUIT BOARD	6 - 8
BLOCK DIAGRAM	9
SCHEMATIC DIAGRAM	10
PARTS LIST	11 - 15
PARTS LIST FOR CARBON RESISTORS	16



このサービスマニュアルは、エコマーク認定の再生紙を使用しています。
This Service Manual uses recycled paper.



■ TO SERVICE PERSONNEL

1. Critical Components Information
Components having special characteristics are marked \triangle and must be replaced with parts having specifications equal to those originally installed.
 2. Leakage Current Measurement (For 120V Models Only)
When service has been completed, it is imperative to verify that all exposed conductive surfaces are properly insulated from supply circuits.
- Meter impedance should be equivalent to 1500 ohm shunted by 0.15 μ F.

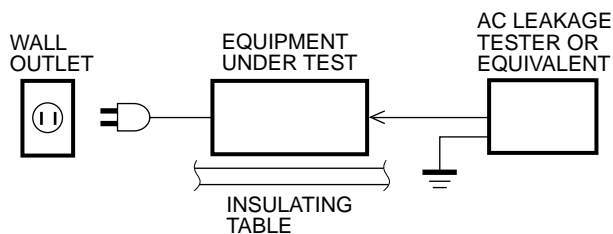

- Leakage current must not exceed 0.5mA.
- Be sure to test for leakage with the AC plug in both polarities.



“CAUTION”

“F1 : FOR CONTINUED PROTECTION AGAINST RISK OF FIRE, REPLACE ONLY WITH SAME TYPE 2.0A, 250V FUSE.”

CAUTION

F1 : REPLACE WITH SAME TYPE 2.0A, 250V FUSE.

ATTENTION

F1 : UTILISER UN FUSIBLE DE RECHANGE DE MEME TYPE DE 2.0A, 250V.

WARNING: CHEMICAL CONTENT NOTICE!

The solder used in the production of this product contains LEAD. In addition, other electrical/electronic and/or plastic (where applicable) components may also contain traces of chemicals found by the California Health and Welfare Agency (and possibly other entities) to cause cancer and/or birth defects or other reproductive harm.

DO NOT PLACE SOLDER, ELECTRICAL/ELECTRONIC OR PLASTIC COMPONENTS IN YOUR MOUTH FOR ANY REASON WHATSOEVER!

Avoid prolonged, unprotected contact between solder and your skin! When soldering, do not inhale solder fumes or expose eyes to solder/flux vapor!

If you come in contact with solder or components located inside the enclosure of this product, wash your hands before handling food.

■ FRONT AND REAR PANELS

▼ Satellite Speakers Front Panel

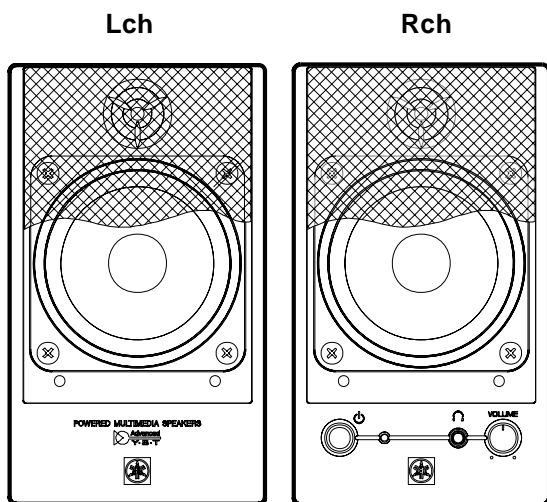

▼ Satellite Speakers Rear Panel

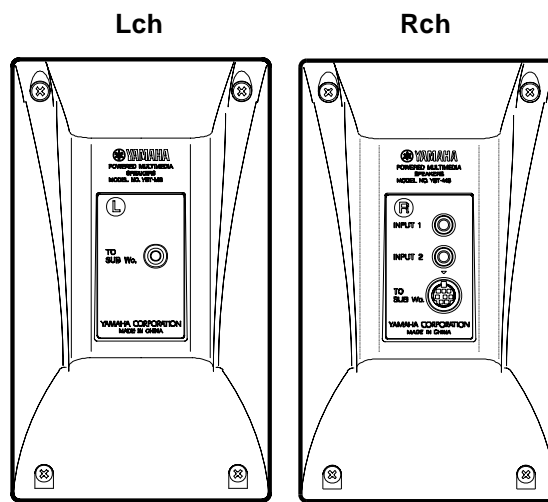

YST-MS50(M)

▼ Subwoofer Front Panel

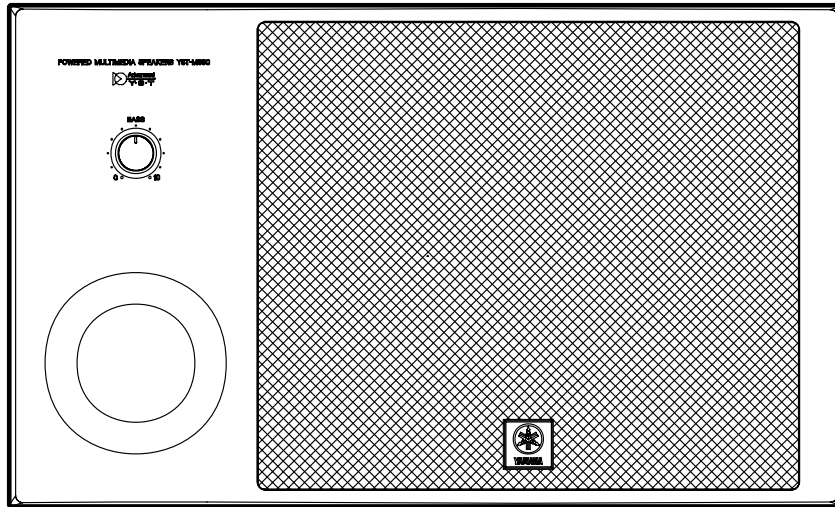

▼ Subwoofer Rear Panel

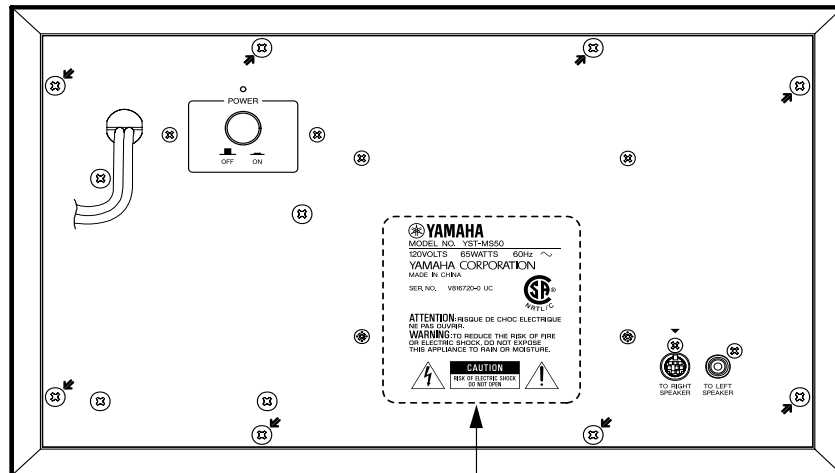

U and C models	B and G models	A model
<p>YAMAHA MODEL NO. YST-MS50 120VOLTS 65WATTS 60Hz ~ YAMAHA CORPORATION MADE IN CHINA SER. NO. V816720-0 UC</p> <p>ATTENTION: RISQUE DE CHOC ELECTRIQUE NE PAS OUVRIR. WARNING: TO REDUCE THE RISK OF FIRE OR ELECTRIC SHOCK, DO NOT EXPOSE THIS APPLIANCE TO RAIN OR MOISTURE.</p> <p>CAUTION RISK OF ELECTRIC SHOCK DO NOT OPEN</p>	<p>YAMAHA MODEL NO. YST-MS50 230VOLTS 65WATTS 50Hz ~ YAMAHA CORPORATION MADE IN CHINA SER. NO. V816740-0 BG</p> <p>CE S EMC QUALIFIED SEMI-ISO</p> <p>CAUTION RISK OF ELECTRIC SHOCK DO NOT OPEN</p>	<p>YAMAHA MODEL NO. YST-MS50 240VOLTS 65WATTS 50Hz ~ YAMAHA CORPORATION MADE IN CHINA SER. NO. V816730-0 A</p> <p>N89</p> <p>CAUTION RISK OF ELECTRIC SHOCK DO NOT OPEN</p>

YST-MS50(M)

■ SPECIFICATIONS

Type Advanced Active Servo Technology

Output Power

Satellite 20W+20W (1kHz, 4 ohms at T.H.D.=10%)

Subwoofer 40W (100Hz, 5 ohms at T.H.D.=10%)

Input Sensitivity 200mV (1kHz, 4 ohms at 20W)

Input Impedance 25 kohms

Frequency Response 32 Hz to 20 kHz

Driver

Satellite

Tweeter 19mm (3/4") balanced dome

Magnetic shielding type

Midrange 8cm (3") cone

Magnetic shielding type

Subwoofer 16cm (6-1/2") cone

Magnetic shielding type

Power Consumption 65 W

Power Supply

U, C models AC120V, 60 Hz

A model AC240V, 50 Hz

B, G models AC230V, 50 Hz

Dimensions (W X H X D)

Satellite 97 x 159 x 178 mm

(3-13/16" x 6-1/4" x 7")

Subwoofer 350 x 210 x 321 mm

(13-3/4" x 8-1/4" x 12-5/8")

Weight

Satellite 0.7 kg (1 lbs. 9 oz) x 2

Subwoofer 8 kg (17 lbs. 10 oz)

Finish White color

Black color

Accessories

3.5mm stereo mini plug cable (1.8m) x 1

RCA pin plug cable (1.8m) x 1

8 pin plug cable (1.8m) x 1

8 pcs of nonskid pad x 1set

● DIMENSIONS

● Satellite Speaker

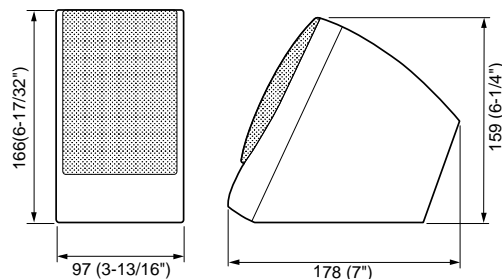

● Subwoofer

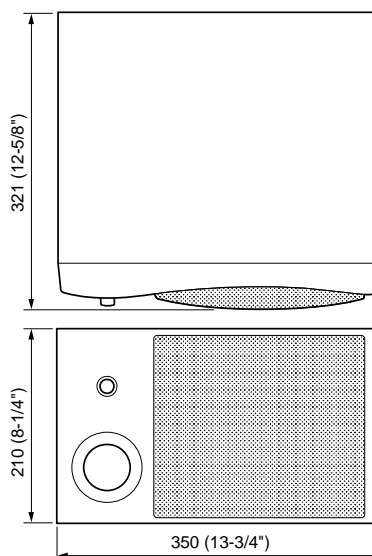

* Specifications subject to change without notice.

Unit : mm (inch)

U USA model

C Canadian model

A Australian model

B British model

G European model

INTERNAL VIEW

▼ Satellite Speakers

Note: The Satellite Speakers are available by the speaker unit (L ch or R ch).
Individual parts of the Satellite Speakers are not available. (See page 14 and 15 of the PARTS LIST.)

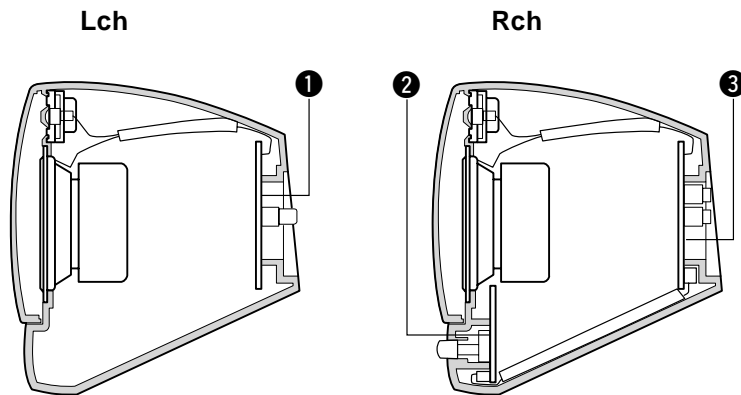

Satellite Speaker (L ch)

- ① MAIN (B) P.C.B.

Satellite Speaker (R ch)

- ② MAIN (C) P.C.B.

- ③ MAIN (D) P.C.B.

▼ Subwoofer

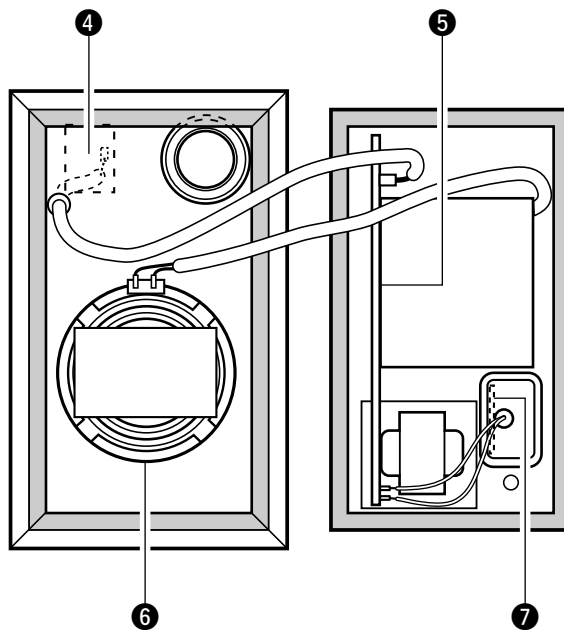

Subwoofer

- ④ MAIN (E) P.C.B.

- ⑤ MAIN (A) P.C.B.

- ⑥ SPEAKER UNIT
(Subwoofer)

- ⑦ MAIN (F) P.C.B.

DISASSEMBLY PROCEDURES

(Remove parts in the order as numbered.)

Disassemble of the Subwoofer

1. Removal of the Rear Panel Ass'y.

- a. Remove 8 screws (①) in Fig. 1, and remove the rear panel ass'y.
- * **Arrow marks (←) are printed to identify the screws to be removed.**
- b. Disconnect one connector in Fig. 1.
- c. Disconnect the Speaker cord in Fig. 1.
- * **When assembling the Rear Panel Ass'y, check to ensure that the packing is not damaged so as to prevent air leakage from occurring.**

2. Removal of the Front Panel Ass'y

The front panel ass'y is fixed to the cabinet with dowels at 6 locations.

* As a screwdriver (for slotted head screw) is used for removal, use special care not to cause damage to the Cabinet.

- a. Using the screwdriver insert in the gaps between the front panel ass'y and cabinet (bottom side first), push up the front panel ass'y.
- b. Remove the front panel ass'y while taking it out. (Front panel ass'y can not to remove completely.)

3. Removal of the Speaker

- a. Set up the front panel ass'y in the direction of the arrow, in Fig. 2.
- b. Remove 4 screws (②) in Fig. 2, and remove the speaker.

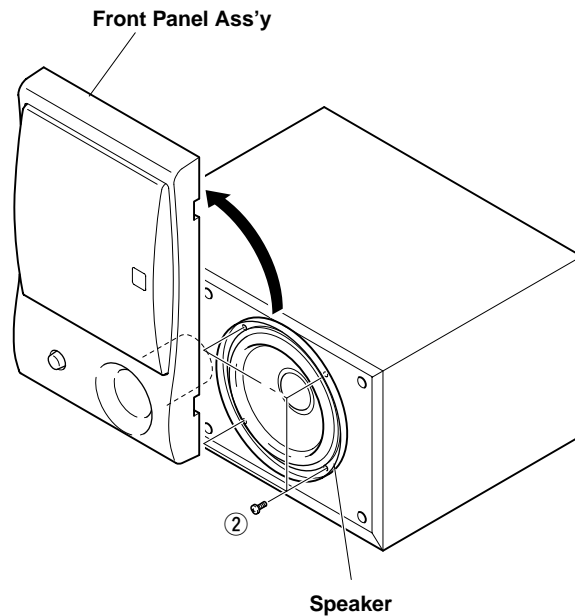

Fig. 2

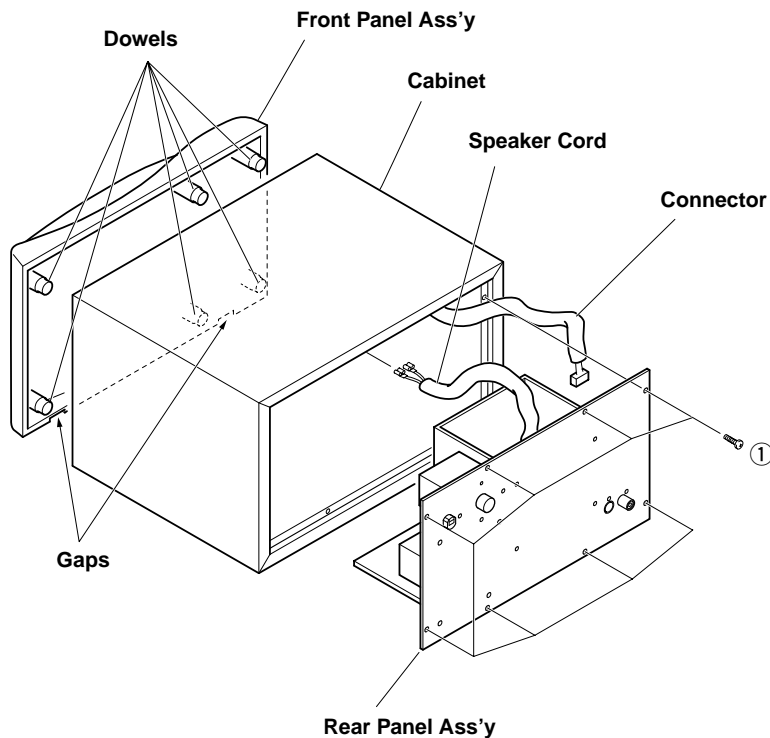

Fig. 1

PRINTED CIRCUIT BOARD (Component side)

Subwoofer

MAIN (A) P. C. B.

TO : SPEAKER (WOOFER)

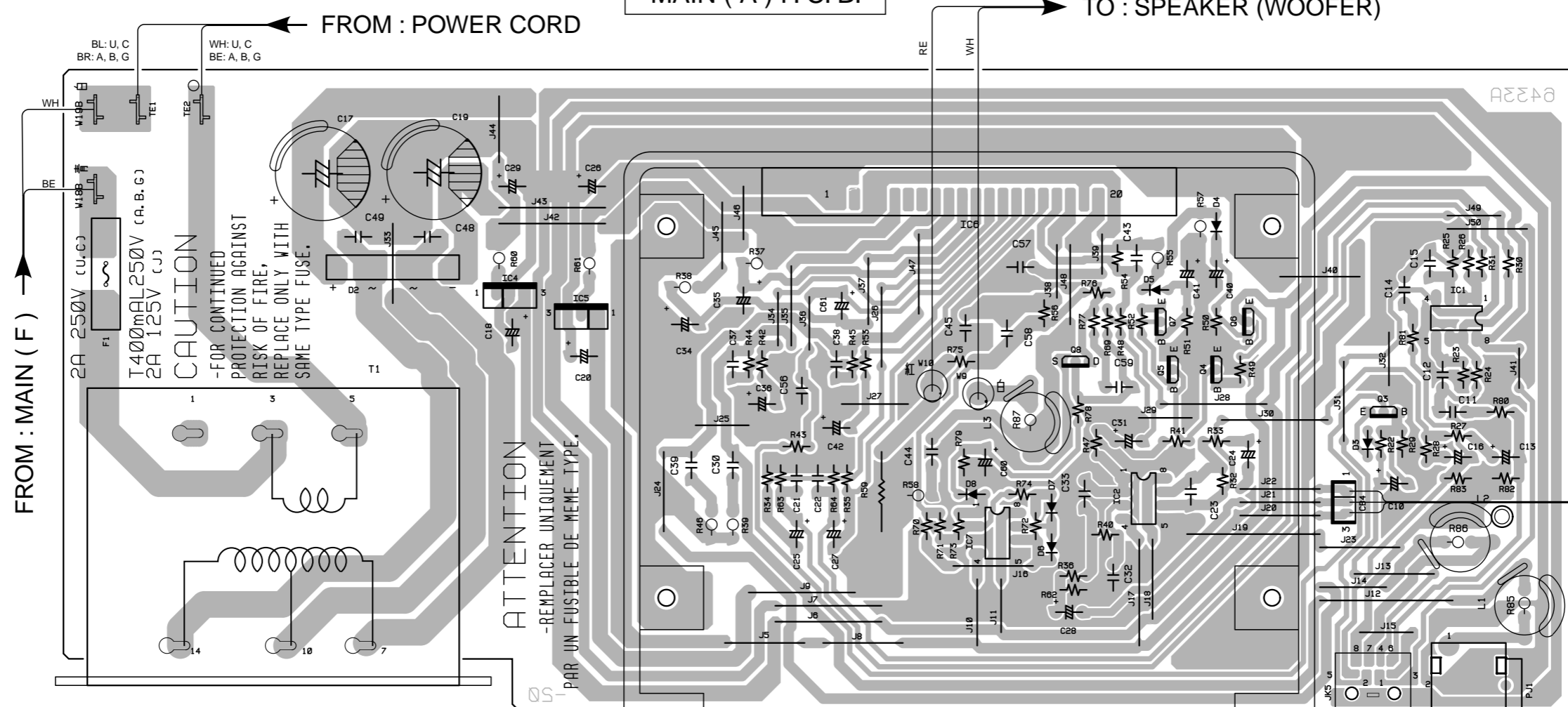

Semiconductor Location

Ref. No.	Location
D2	B2
D3	F3
D4	F2
D5	E2
D6	E3
D7	E3
D8	E3

Ref. No.	Location
IC1	F2
IC2	E3
IC4	C2
IC5	C2
IC6	E2
IC7	E3

Ref. No.	Location
Q3	F3
Q4	F2
Q5	F2
Q7	E2
Q8	E2

Satellite Speaker (L ch)

MAIN (B) P. C. B.

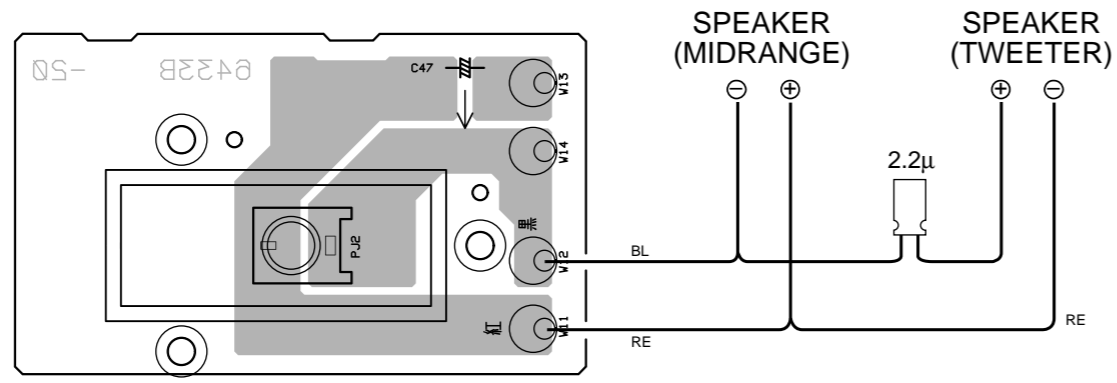

MAIN (E) P. C. B.

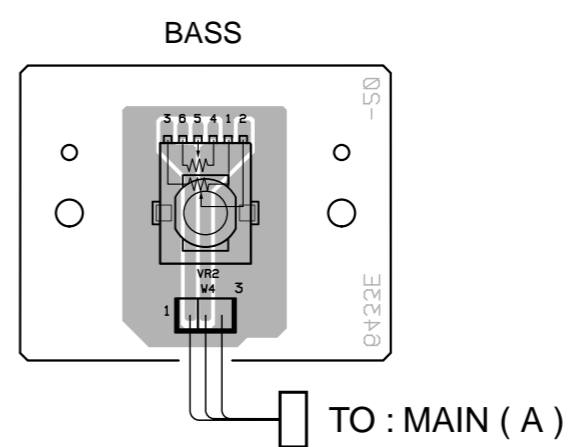

MAIN (F) P. C. B.

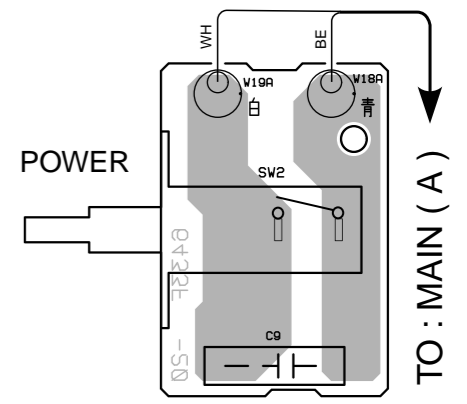

1

2

3

4

5

6

PRINTED CIRCUIT BOARD (Component side)

Satellite Speaker (R ch)

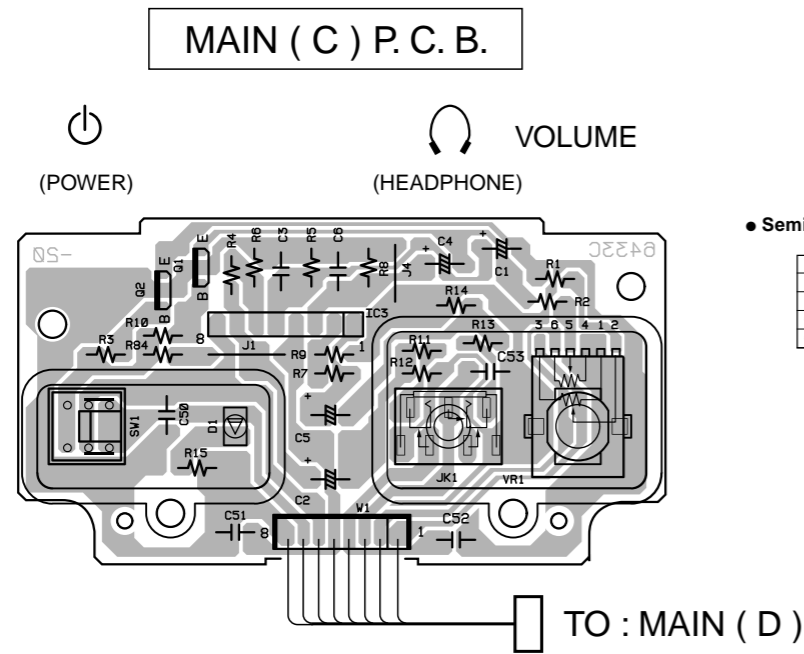

Semiconductor Location

Ref. No.	Location
IC3	B2
Q1	B2
Q2	B2

MAIN (D) P.C.B.

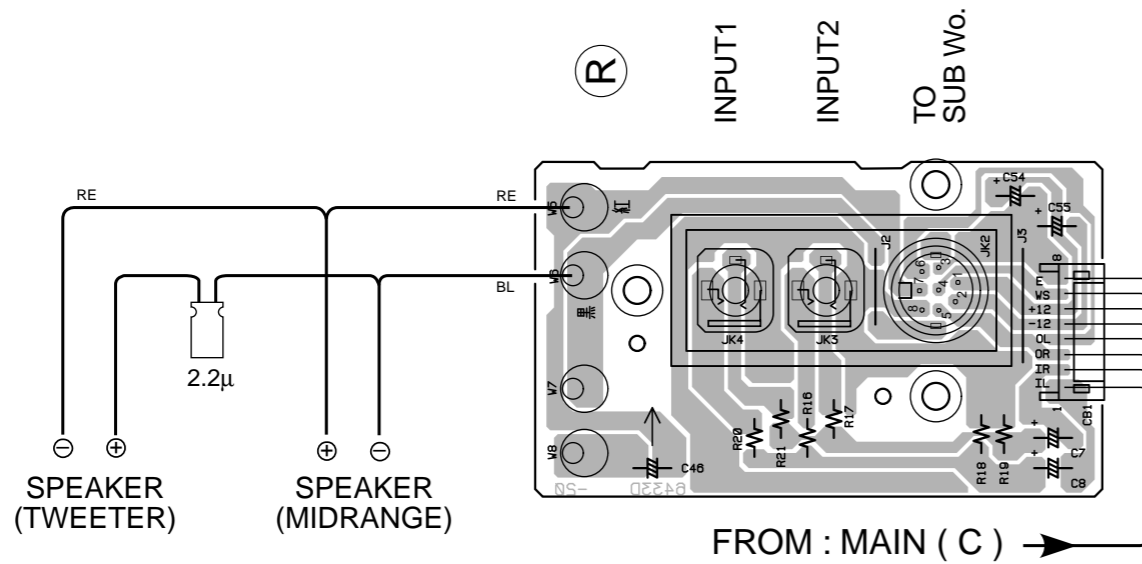

BLOCK DIAGRAM

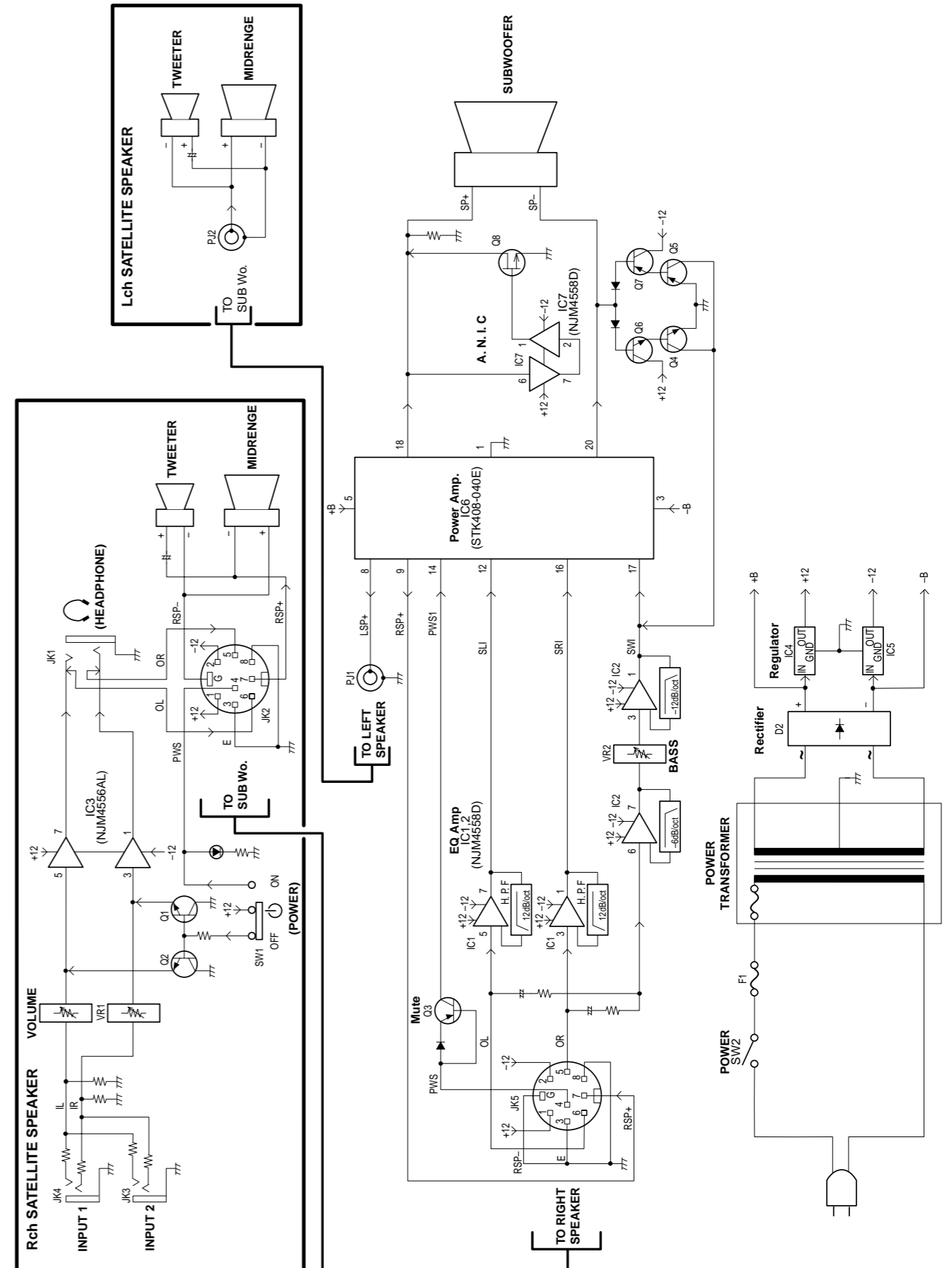

SCHEMATIC DIAGRAM

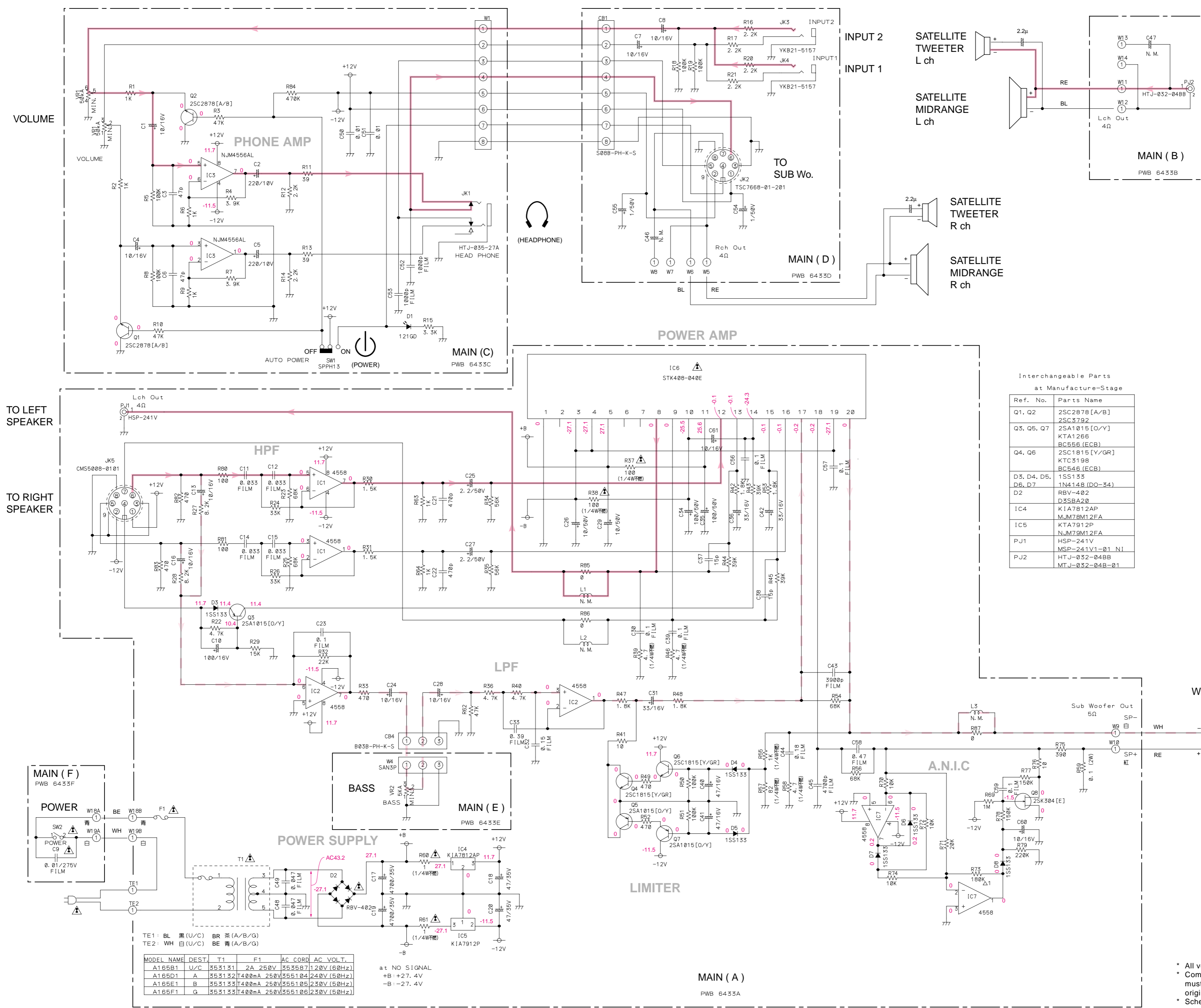

PIN CONNECTION DIAGRAM OF TRANSISTORS, DIODES AND ICs.

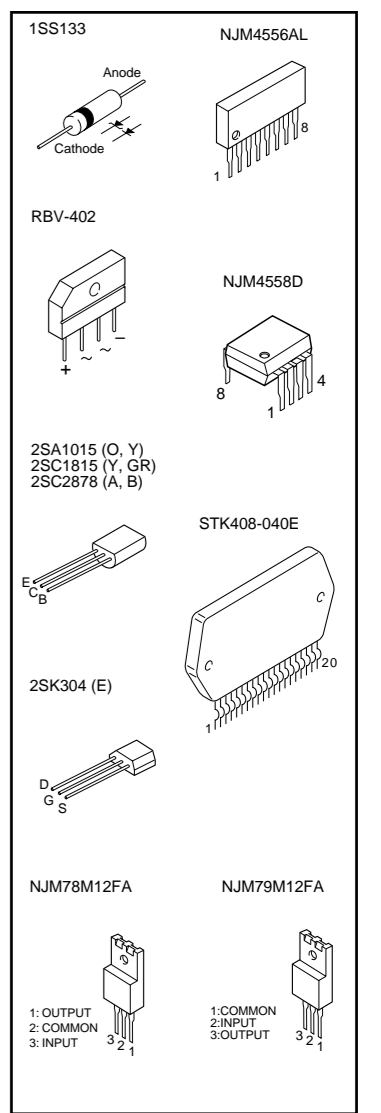

Interchangeable Parts at Manufacture-Stage

Ref. No.	Parts Name
Q1, Q2	2SC2878 [A/B]
Q3, Q5, Q7	2SA1015 [O/Y]
Q4, Q6	2SC1815 [Y/GR]
D3, D4, D5, D6, D7	1N4148 (DO-34)
D2	RBV-402
IC4	K1A7812AP
IC5	K1A7912P
PJ1	HSP-241V
PJ2	MSP-241V1-01 NI

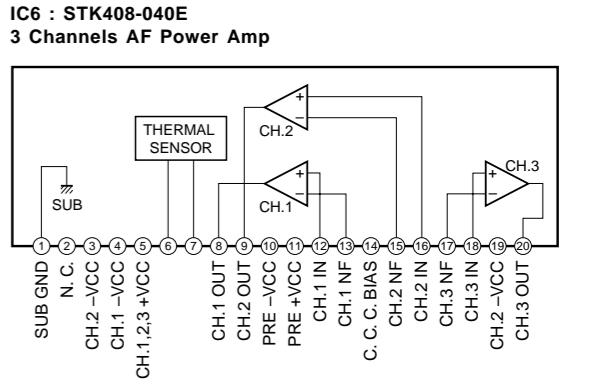
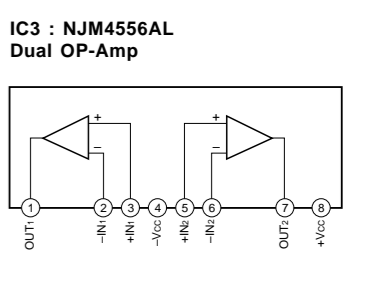
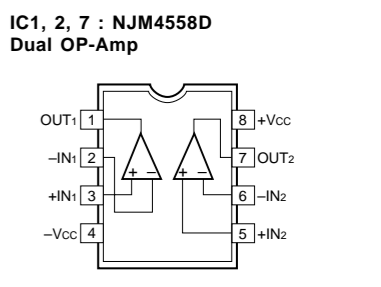

MODEL NAME	DEST.	T1	F1	AC CORD	AC VOLT.
A165B1	U/C	353131	2A	250V	353587 [120V (60Hz)]
A165D1	A	353132	1400mA	250V	355104 [240V (50Hz)]
A165E1	B	353133	1400mA	250V	355105 [230V (50Hz)]
A165F1	G	353133	1400mA	250V	355106 [230V (50Hz)]

* All voltage are measured with a 10MΩ/V DC electric volt meter.
 * Components having special characteristics are marked Δ and must be replaced with parts having specifications equal to those originally installed.
 * Schematic diagram is subject to change without notice.

PARTS LIST

■ ELECTRICAL PARTS

■ WARNING

Components having special characteristics are marked \triangle and must be replaced with parts having specifications equal to those originally installed.

- Carbon resistors (1/6W or 1/4W) are not included in the ELECTRICAL PARTS List. For the parts No. of the carbon resistors, refer to last page.

ABBREVIATIONS IN THIS LIST ARE AS FOLLOWS :

C.A.EL.CHP	: CHIP ALUMI. ELECTROLYTIC CAP	L.EMIT	: LIGHT EMITTING MODULE
C.CE	: CERAMIC CAP	LED.DSPLY	: LED DISPLAY
C.CE.ARRAY	: CERAMIC CAP ARRAY	LED.INFRD	: LED, INFRARED
C.CE.CHP	: CHIP CERAMIC CAP	MODUL.RF	: MODULATOR, RF
C.CE.ML	: MULTILAYER CERAMIC CAP	PHOT.CPL	: PHOTO COUPLER
C.CE.M.CHP	: CHIP MULTILAYER CERAMIC CAP	PHOT.INTR	: PHOTO INTERRUPTER
C.CE.SAFTY	: RECOGNIZED CERAMIC CAP	PHOT.RFLCT	: PHOTO REFLECTOR
C.CE.TUBLR	: CERAMIC TUBULAR CAP	PIN.TEST	: PIN, TEST POINT
C.CE.SMI	: SEMI CONDUCTIVE CERAMIC CAP	PLST.RIVET	: PLASTIC RIVET
C.EL	: ELECTROLYTIC CAP	R.ARRAY	: RESISTOR ARRAY
C.MICA	: MICA CAP	R.CAR	: CARBON RESISTOR
C.ML.FLM	: MULTILAYER FILM CAP	R.CAR.CHP	: CHIP RESISTOR
C.MP	: METALLIZED PAPER CAP	R.CAR.FP	: FLAME PROOF CARBON RESISTOR
C.MYLAR	: MYLAR FILM CAP	R.FUS	: FUSABLE RESISTOR
C.MYLAR.ML	: MULTILAYER MYLAR FILM CAP	R.MTL.CHP	: CHIP METAL FILM RESISTOR
C.PAPER	: PAPER CAPACITOR	R.MTL.FLM	: METAL FILM RESISTOR
C.PLS	: POLYSTYRENE FILM CAP	R.MTL.OXD	: METAL OXIDE FILM RESISTOR
C.POL	: POLYESTER FILM CAP	R.MTL.PLAT	: METAL PLATE RESISTOR
C.POLY	: POLYETHYLENE FILM CAP	RSNR.CE	: CERAMIC RESONATOR
C.PP	: POLYPROPYLENE FILM CAP	RSNR.CRYS	: CRYSTAL RESONATOR
C.TNTL	: TANTALUM CAP	R.TW.CEM	: TWIN CEMENT FIXED RESISTOR
C.TNTL.CHP	: CHIP TANTALUM CAP	R.WW	: WIRE WOUND RESISTOR
C.TRIM	: TRIMMER CAP	SCR.BND.HD	: BIND HEAD B-TITE SCREW
CN	: CONNECTOR	SCR.BW.HD	: BW HEAD TAPPING SCREW
CN.BS.PIN	: CONNECTOR, BASE PIN	SCR.CUP	: CUP TITE SCREW
CN.CANNON	: CONNECTOR, CANNON	SCR.TERM	: SCREW TERMINAL
CN.DIN	: CONNECTOR, DIN	SCR.TR	: SCREW, TRANSISTOR
CN.FLAT	: CONNECTOR, FLAT CABLE	SUPRT.PCB	: SUPPORT, P.C.B.
CN.POST	: CONNECTOR, BASE POST	SURG.PRTCT	: SURGE PROTECTOR
COIL.MX.AM	: COIL, AM MIX	SW.TACT	: TACT SWITCH
COIL.AT.FM	: COIL, FM ANTENNA	SW.LEAF	: LEAF SWITCH
COIL.DT.FM	: COIL, FM DETECT	SW.LEVER	: LEVER SWITCH
COIL.MX.FM	: COIL, FM MIX	SW.MICRO	: MICRO SWITCH
COIL.OUTPT	: OUTPUT COIL	SW.PUSH	: PUSH SWITCH
DIOD.ARRAY	: DIODE ARRAY	SW.RT.ENC	: ROTARY ENCODER
DIODE.BRG	: DIODE BRIDGE	SW.RT.MTR	: ROTARY SWITCH WITH MOTOR
DIODE.CHP	: CHIP DIODE	SW.RT	: ROTARY SWITCH
DIODE.VAR	: VARACTOR DIODE	SW.SLIDE	: SLIDE SWITCH
DIOD.Z.CHP	: CHIP ZENER DIODE	TERM.SP	: SPEAKER TERMINAL
DIODE.ZENR	: ZENER DIODE	TERM.WRAP	: WRAPPING TERMINAL
DSCR.CE	: CERAMIC DISCRIMINATOR	THRMST.CHP	: CHIP THERMISTOR
FER.BEAD	: FERRITE BEADS	TR.CHP	: CHIP TRANSISTOR
FER.CORE	: FERRITE CORE	TR.DGT	: DIGITAL TRANSISTOR
FET.CHP	: CHIP FET	TR.DGT.CHP	: CHIP DIGITAL TRANSISTOR
FL.DSPLY	: FLUORESCENT DISPLAY	TRANS	: TRANSFORMER
FLTR.CE	: CERAMIC FILTER	TRANS.PULS	: PULSE TRANSFORMER
FLTR.COMB	: COMB FILTER MODULE	TRANS.PWR	: POWER TRANSFORMER ASS'y
FLTR.LC.RF	: LC FILTER, EMI	TUNER.AM	: TUNER PACK, AM
GND.MTL	: GROUND PLATE	TUNER.FM	: TUNER PACK, FM
GND.TERM	: GROUND TERMINAL	TUNER.PK	: FRONT-END TUNER PACK
HOLDER.FUS	: FUSE HOLDER	VR	: ROTARY POTENTIOMETER
IC.PRTCT	: IC PROTECTOR	VR.MTR	: POTENTIOMETER WITH MOTOR
JUMPER.CN	: JUMPER CONNECTOR	VR.SW	: POTENTIOMETER WITH ROTARY SW
JUMPER.TST	: JUMPER, TEST POINT	VR.SLIDE	: SLIDE POTENTIOMETER
L.DTCT	: LIGHT DETECTING MODULE	VR.TRIM	: TRIMMER POTENTIOMETER

Note) Those parts marked with “#” are not included in the P.C.B. ass'y.

P.C.B. MAIN

Schm Ref.	PART NO.	Description	Remarks
*	AAX31030	P. C. B.	(UC) 353086
*	AAX31040	P. C. B.	(ABG) 353090
CB1	VB858700	CN.BS.PIN	8P
CB4	VD004600	CN.BS.PIN	3P
CB5	VP206500	HOLDER.FUS	EYF-52BC
CB6	VP206500	HOLDER.FUS	EYF-52BC
C1	VJ836900	C.EL	10uF 16V
C2	VV020100	C.EL	220uF 10V
C3	FG211470	C.CE	47pF 50V
C4	VJ836900	C.EL	10uF 16V
C5	VV020100	C.EL	220uF 10V
C6	FG211470	C.CE	47pF 50V
C7	VJ836900	C.EL	10uF 16V
C8	VJ836900	C.EL	10uF 16V
△ C9	VS741700	C.CE.SAFTY	0.01uF 275V
C10	VF964800	C.EL	100uF 16V
C11	UA654330	C.MYLAR	0.033uF 50V
C12	UA654330	C.MYLAR	0.033uF 50V
C13	VJ836900	C.EL	10uF 16V
C14	UA654330	C.MYLAR	0.033uF 50V
C15	UA654330	C.MYLAR	0.033uF 50V
C16	VJ836900	C.EL	10uF 16V
C17	UR759470	C.EL	4700uF 35V
C18	UR857470	C.EL	47uF 35V
C19	UR759470	C.EL	4700uF 35V
C20	UR857470	C.EL	47uF 35V
C21	FG212470	C.CE	470pF 50V
C22	FG212470	C.CE	470pF 50V
C23	UA655100	C.MYLAR	0.1uF 50V
C24	VJ836900	C.EL	10uF 16V
C25	UR866220	C.EL	2.2uF 50V
C26	UR867100	C.EL	10uF 50V
C27	UR866220	C.EL	2.2uF 50V
C28	VJ836900	C.EL	10uF 16V
C29	UR867100	C.EL	10uF 50V
C30	UA655100	C.MYLAR	0.1uF 50V
C31	UM397330	C.EL	33uF 16V
C32	UA655150	C.MYLAR	0.15uF 50V
C33	UA655390	C.MYLAR	0.39uF 50V
C34	UJ668100	C.EL	100uF 50V
C35	UJ668100	C.EL	100uF 50V
C36	UM397330	C.EL	33uF 16V
C37	FG211150	C.CE	15pF 50V
C38	FG211150	C.CE	15pF 50V
C39	UA655100	C.MYLAR	0.1uF 50V
C40	VJ837200	C.EL	47uF 16V
C41	VJ837200	C.EL	47uF 16V
C42	UM397330	C.EL	33uF 16V
C43	UA653390	C.MYLAR	3900pF 50V
C44	UA655180	C.MYLAR	0.18uF 50V
C45	UA653470	C.MYLAR	4700pF 50V
C46	VD916400	C.EL	2.2uF 50V
C47	VD916400	C.EL	2.2uF 50V

* New Parts

Schm Ref.	PART NO.	Description	Remarks
C48	UA654470	C.MYLAR	0.047uF 50V
C49	UA654470	C.MYLAR	0.047uF 50V
C50	FG214100	C.CE	0.01uF 50V
C51	FG214100	C.CE	0.01uF 50V
C52	UA653100	C.MYLAR	1000pF 50V
C53	UA653100	C.MYLAR	1000pF 50V
C54	VJ839100	C.EL	1uF 50V
C55	VJ839100	C.EL	1uF 50V
C56	UA655100	C.MYLAR	0.1uF 50V
C57	UA655100	C.MYLAR	0.1uF 50V
C58	UA655470	C.MYLAR	0.47uF 50V
C59	UA655100	C.MYLAR	0.1uF 50V
C60	VJ836900	C.EL	10uF 16V
C61	VJ836900	C.EL	10uF 16V
D1	VY660300	LED(gr)	SLP-277B-51
△ D2	VC971500	DIODE.BRG	RBV-402 4.0A 200V
D3	iF004600	DIODE	1SS133
D4	iF004600	DIODE	1SS133
D5	iF004600	DIODE	1SS133
D6	iF004600	DIODE	1SS133
D7	iF004600	DIODE	1SS133
D8	iF004600	DIODE	1SS133
△ F1	KB000660	FUSE	400mA 250V(ABG)
△ F1	VT951300	FUSE	2A 250V (UC)
IC1	XN324A00	IC	NJM4558DV
IC2	XN324A00	IC	NJM4558DV
IC3	XP844A00	IC	NJM4556AL
IC4	XJ602A00	IC	NJM78M12FA
IC5	XD343A00	IC	NJM79M12FA
△ IC6	XV809A00	IC	STK408-040E 25W
IC7	XN324A00	IC	NJM4558DV
JK1	V3666400	JACK.MNI	HTJ-035-27A
JK2	V3317500	JACK.DIN	8P
JK3	V3317400	JACK.MNI	1P
JK4	V3317400	JACK.MNI	1P
JK5	VV881000	CN.DIN	8P CMS5008-0101
PJ1	V3407500	JACK.PIN	1P
PJ2	VU581900	JACK.PIN	1P
Q1	iC287820	TR	2SC2878 A,B
Q2	iC287820	TR	2SC2878 A,B
Q3	iA101590	TR	2SA1015 O,Y
Q4	iC1815M0	TR	2SC1815 Y,GR
Q5	iA101590	TR	2SA1015 O,Y
Q6	iC1815M0	TR	2SC1815 Y,GR
Q7	iA101590	TR	2SA1015 O,Y
Q8	V3028000	FET	2SK304 E
△ R37	HV455100	R.CAR.FP	100 1/4W
△ R38	HV455100	R.CAR.FP	100 1/4W
R39	HV453470	R.CAR.FP	4.7 1/4W
R46	HV453470	R.CAR.FP	4.7 1/4W
R55	HV456100	R.CAR.FP	1K 1/4W
R57	HV454820	R.CAR.FP	82 1/4W
R58	HV453470	R.CAR.FP	4.7 1/4W

* New Parts

YST-MS50(M)

P.C.B. MAIN

Schm Ref.	PART NO.	Description	Remarks
R59	VE869300	R. MTL. OXD	0.1 2W
△ R60	HV453100	R. CAR. FP	1 1/4W
△ R61	HV453100	R. CAR. FP	1 1/4W
SW1	VS066500	SW. PUSH	SPPH13-W
△ * SW2	V8377400	SW. POWER	SY16-52-4 354986
VR1	V2261700	VR	A50K
VR2	VZ496100	VR	A5K
	BB070700	GND. MTL	
	V4097600	HOLDER. LED	LH-5-14
	Ei030086	SCR. BND. HD	3x8 MFZN2Y
	Ei330166	SCR. BND. HD	3x16 MFC2BL

* New Parts

Schm Ref.	PART NO.	Description	Remarks
-----------	----------	-------------	---------

* New Parts

YST-MS50(M)

1 ■ EXPLODED VIEW

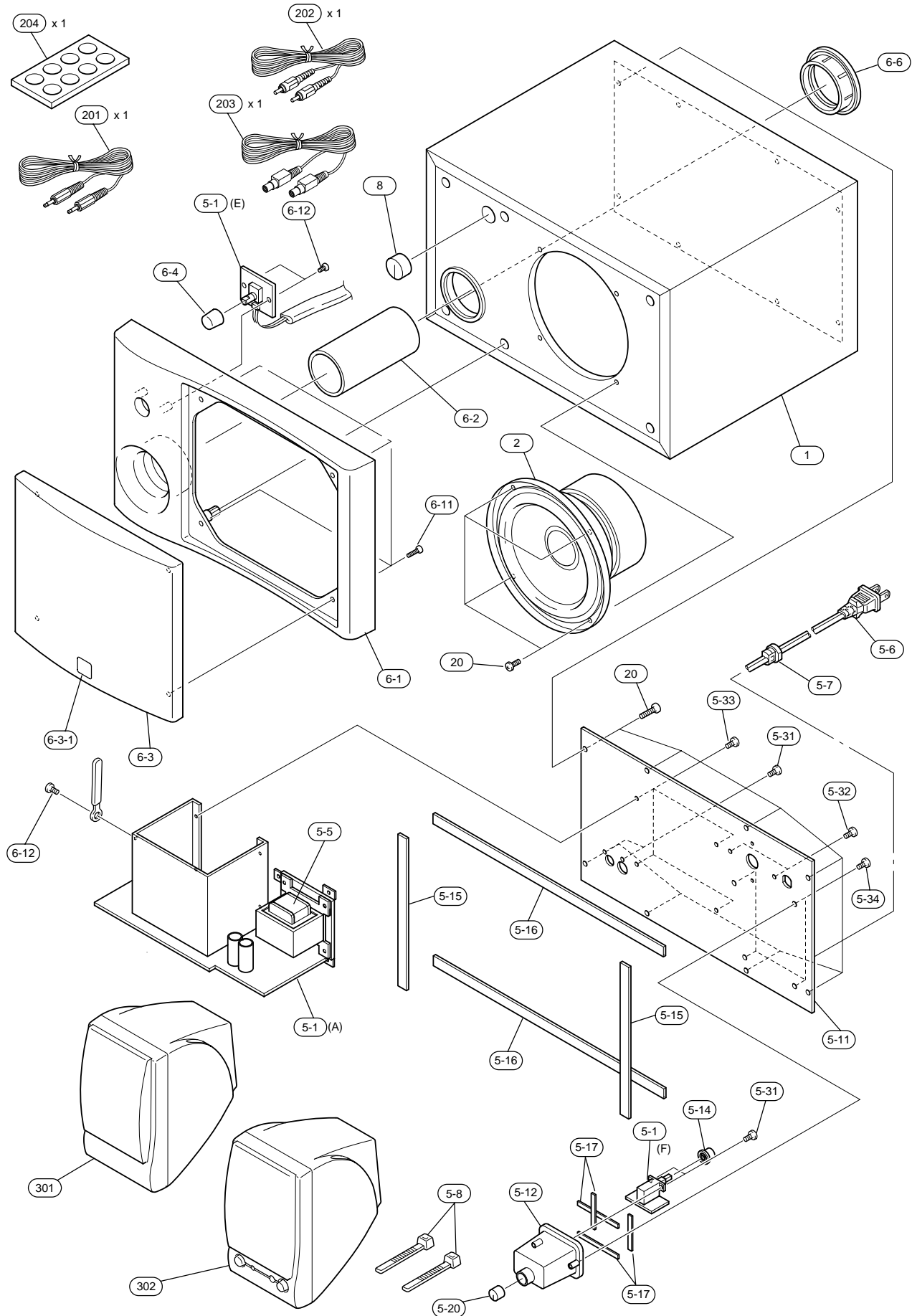

MECHANICAL PARTS

Ref. No.	PART NO.	Description	Remarks	Markets	
* 1	AAX31070	CABINET ASS'Y	WH	353458	
* 1	AAX31060	CABINET ASS'Y	BL	353457	
* 2	X2009A00	DRIVER, WOOFER	16cm JA1687	353214	
* 5-1	AAX31030	P.C.B. ASS'Y	MAIN	353086	UC
* 5-1	AAX31040	P.C.B. ASS'Y	MAIN	353090	ABG
△ * 5-5	X2113A00	POWER TRANSFORMER		353131	UC
△ * 5-5	X2114A00	POWER TRANSFORMER		353132	A
△ * 5-5	X2115A00	POWER TRANSFORMER		353133	BG
△ * 5-6	V8366300	POWER CORD		353587	UC
△ * 5-6	V8366500	POWER CORD		355104	A
△ * 5-6	V8366600	POWER CORD		355105	B
△ * 5-6	V8366400	POWER CORD		355106	G
	5-7	CB072750	CORD STOPPER	SR-4N-4	078569
	5-8	CB069250	BINDING TIE	BK-1	080558
* 5-11	AAX31170	REAR PANEL		353582	UC
* 5-11	AAX31180	REAR PANEL		353583	A
* 5-11	AAX31190	REAR PANEL		353584	BG
* 5-12	AAX31050	COVER		352528	
* 5-14	AAX31020	BUTTON POWER		352529	
	5-15	V2583100	PACKING, A		044414
	5-16	V2583200	PACKING, B		044415
* 5-17	AAX31130	PACKING, MOLD	5x55		335431
	5-20	VZ655300	BUSH		084849
	5-31	EN335030	BIND HEAD BONDING TAP. SCREW	3x10 MFC2BL	075321
	5-32	EX601360	BIND HEAD P-TITE SCREW	3x10 MFC2BL	
	5-33	ED330086	BIND HEAD SCREW	3x8 MFC2BL	075573
	5-34	EK396010	BIND HEAD S-TITE SCREW	4x8 MFC2BL	075180
	6-1	V3370900	FRONT PANEL	WH	049622
	6-1	V3371000	FRONT PANEL	BL	049623
	6-2	V3374600	PORT		050337
* 6-3	AAX31150	FRONT GRILLE ASS'Y	WH		353371
* 6-3	AAX31160	FRONT GRILLE ASS'Y	BL		353372
	6-3-1	V3371600	EMBLEM		
	6-4	V3374700	KNOB, VOLUME	WH	049656
	6-4	V3374800	KNOB, VOLUME	BL	049677
	6-6	V2490000	PORT RING		044359
	6-11	EK093030	BIND HEAD P-TITE SCREW	3x10 MFZN2Y	
	6-12	EP600280	BIND HEAD P-TITE SCREW	3x8 MFZN2Y	018079
	8	VZ655300	BUSH		084849
	20	Ei340206	BIND HEAD TAPPING SCREW	4x20 MFZN2BL	
		ACCESSORIES			
	201	VS494400	CABLE, MINI PLUG	1.8m 1pc	040878
	202	VT309500	RCA PIN CABLE	1.8m 1pc	019086
	203	VZ663800	DIN PLUG CABLE	8P 1.8m 1pc	354879
	204	VS104300	NON SKID PAD	8pcs/set	011716
* 301	AAX31080	SATELLITE SPEAKER UNIT	L WH		351937L
* 301	AAX31100	SATELLITE SPEAKER UNIT	L BL		351942L
* 302	AAX31090	SATELLITE SPEAKER UNIT	R WH		351937R
* 302	AAX31110	SATELLITE SPEAKER UNIT	R BL		351942R

* New Parts

Parts List for Carbon Resistors

Value	1/4W Type Part No.	1/6W Type Part No.	Value	1/4W Type Part No.	1/6W Type Part No.
1.0 Ω	HJ35 3100	HF85 3100	10 kΩ	HF45 7100	HF45 7100
1.8 Ω	HJ35 3180	*	11 kΩ	HF45 7110	HF45 7110
2.2 Ω	HJ35 3220	HF85 3220	12 kΩ	HJ35 7120	HF85 7120
3.3 Ω	HJ35 3330	HF85 3330	13 kΩ	HF45 7130	HF45 7130
4.7 Ω	HJ35 3470	HF85 3470	15 kΩ	HF45 7150	HF45 7150
5.6 Ω	HJ35 3560	HF85 3560	18 kΩ	HF45 7180	HF45 7180
10 Ω	HF45 4100	HF45 4100	22 kΩ	HF45 7220	HF45 7220
15 Ω	HJ35 4150	HF85 4150	24 kΩ	HF45 7240	HF45 7240
22 Ω	HF45 4220	HF45 4220	27 kΩ	HJ35 7270	HF85 7270
27 Ω	HJ35 4270	HF85 4270	30 kΩ	HF45 7300	HF45 7300
33 Ω	HF45 4330	HF45 4330	33 kΩ	HF45 7330	HF45 7330
39 Ω	HJ35 4470	HF85 4390	36 kΩ	HF45 7360	HF45 7360
47 Ω	HF45 4470	HF45 4470	39 kΩ	HF45 7390	HF45 7390
56 Ω	HF45 4560	HF45 4560	47 kΩ	HF45 7470	HF45 7470
68 Ω	HF45 4680	HF45 4680	51 kΩ	HF45 7510	HF45 7510
75 Ω	HF45 4750	HF45 4750	56 kΩ	HF45 7560	HF45 7560
82 Ω	HF45 4820	HF45 4820	62 kΩ	HF45 7620	HF45 7620
91 Ω	HF45 4910	HF45 4910	68 kΩ	HF45 7680	HF45 7680
100 Ω	HF45 5100	HF45 5100	82 kΩ	HF45 7820	HF45 7820
110 Ω	HJ35 5110	HF85 5110	91 kΩ	HF45 7910	HF45 7910
120 Ω	HF45 5120	HF45 5120	100 kΩ	HF45 8100	HF45 8100
150 Ω	HF45 5150	HF45 5150	110 kΩ	HF45 8110	HF45 8110
160 Ω	HJ35 5160	*	120 kΩ	HF45 8120	HF45 8120
180 Ω	HF45 5180	HF45 5180	150 kΩ	HF45 8150	HF45 8150
200 Ω	HF45 5200	HF45 5200	180 kΩ	HF45 8180	HF45 8180
220 Ω	HF45 5220	HF45 5220	220 kΩ	HJ35 8220	HF85 8220
270 Ω	HF45 5270	HF45 5270	270 kΩ	HF45 8270	HF45 8270
330 Ω	HF45 5330	HF45 5330	300 kΩ	HF45 8300	HF45 8300
390 Ω	HF45 5390	HF45 5390	330 kΩ	HF45 8330	HF45 8330
430 Ω	HF45 5430	HF45 5430	390 kΩ	HJ35 8390	HF85 8390
470 Ω	HF45 5470	HF45 5470	470 kΩ	HF45 8470	HF45 8470
510 Ω	HF45 5510	HF45 5510	560 kΩ	HJ35 8560	HF85 8560
560 Ω	HF45 5560	HF45 5560	680 kΩ	HJ35 8680	HF85 8680
680 Ω	HF45 5680	HF45 5680	820 kΩ	HJ35 8820	HF85 8820
820 Ω	HF45 5820	HF45 5820	1.0 MΩ	HF45 9100	HF45 9100
910 Ω	HF45 5910	HF45 5910	1.2 MΩ	HJ35 9120	*
1.0 kΩ	HF45 6100	HF45 6100	1.5 MΩ	HJ35 9150	HF85 9150
1.2 kΩ	HF45 6120	HF45 6120	1.8 MΩ	HJ35 9180	HF85 9180
1.5 kΩ	HF45 6150	HF45 6150	2.2 MΩ	HJ35 9220	HF85 9220
1.8 kΩ	HF45 6180	HF45 6180	3.3 MΩ	HJ35 9330	HF85 9330
2.0 kΩ	HJ35 6200	HF85 6200	3.9 MΩ	HJ35 9390	*
2.2 kΩ	HF45 6220	HF45 6220	4.7 MΩ	HJ35 9470	HF85 9470
2.4 kΩ	HJ35 6240	HF85 6240			
2.7 kΩ	HF45 6270	HF45 6270			
3.0 kΩ	HF45 6300	HF45 6300			
3.3 kΩ	HF45 6330	HF45 6330			
3.6 kΩ	HJ35 6360	HF85 6360			
3.9 kΩ	HF45 6390	HF45 6390			
4.7 kΩ	HF45 6470	HF45 6470			
5.1 kΩ	HF45 6510	HF45 6510			
5.6 kΩ	HF45 6560	HF45 6560			
6.8 kΩ	HF45 6680	HF45 6680			
8.2 kΩ	HF45 6820	HF45 6820			
9.1 kΩ	HF45 6910	HF45 6910			

1/4W Type

HJ35 ○○○○

← 10mm →

1/4W Type

HF45 ○○○○

← 5mm →

1/6W Type

HF85 ○○○○

← 5mm →